

Food Processing Equipment

- Vegetable Cutter & Food Cut Up Machine
- Potato Peeler
- Meat Grinder & Cheese Grinder
- Meat Slicer & Dicer
- Sausage Filler
- Filling Mixer
- Bone Saw Machine



Vegetable Cutter & Food Cut Up Machine

Vegetable Cutter

Description

- With 6 different disc
- High grade stainless steel material
- Safety cover device
- Ideal for various slicing and shredding needs
- Skidproof feet

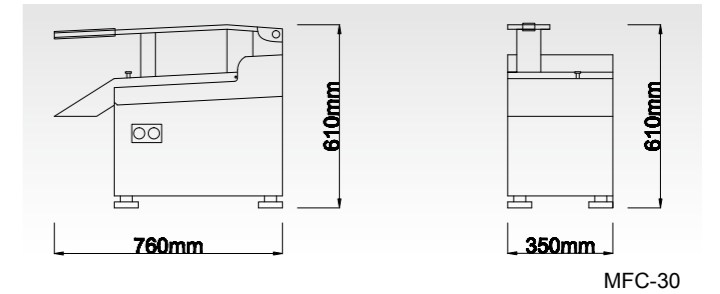

VC55 MF

Dimension(LxWxH): 580×300×540mm
Voltage: 220V/50Hz
Power: 550Kw
Accessories:
Grater discs: 3mm, 4.5mm, 7mm
Slicer discs: 2mm, 4mm
Drain disc
N.W./G.W.: 23/26 kgs

VC65 MS

Dimension(LxWxH): 655×325×535mm
Voltage: 220V/50Hz
Power: 0.75Kw
Accessories:
Grater discs: 3mm, 4.5mm, 7mm
Slicer discs: 2mm, 4mm
Drain disc
N.W./G.W.: 26/30Kgs

MFC-23

Dimension(LxWxH): 275×580×455mm
Voltage: 220V/50Hz
Power: 0.25Kw
Disc diameter: 204mm
Production: 120Kg/h
N.W./G.W.: 30/41Kgs

MFC-30

Dimension(LxWxH): 350×760×610mm
Voltage: 220V/50Hz
Power: 0.75Kw
Disc diameter: 300mm
Production: 150Kg/h
N.W./G.W.: 50/79Kgs

FOOD CUT UP MACHINE

Description

- Mainly used for cutting to make stuffing
- The machine is driven by worm wheel and worm-type speed-down gears
- Equipped with a protective device to ensure safety
- Food contact parts are made of anti-corrosion Aluminium alloy or stainless steel



TQ5

Dimension(LxWxH): 525×420×550mm
Voltage: 220V/50Hz
Power: 0.37Kw
Production capacity: 5L
Production: 80Kg/h
N.W./G.W.: 47/59Kgs



TQ8

Dimension(LxWxH): 800×550×550mm
Voltage: 220V/50Hz
Power: 0.75Kw
Production capacity: 8L
Production: 120Kg/h
N.W./G.W.: 82/100Kgs

QS620A

Dimension(LxWxH): 775×710×940mm
Voltage: 220V/50Hz
Power: 1.5/1.1Kw
Production capacity: 20L
Production: 120Kg/h
N.W.: 128/157Kgs

QS630

Dimension(LxWxH): 990×810×980mm
Voltage: 380V/50Hz
Power: 2.2/2.8Kw
Production capacity: 25L
Production: 300Kg/h
N.W./G.W.: 242/318Kgs

QS650

Dimension(LxWxH): 1200×1000×1138mm
Voltage: 380V/50Hz
Power: 2.2/2.8Kw
Production capacity: 50L
Production: 1000Kg/h
N.W./G.W.: 319/403Kgs

Potato Peeler

Description

- High efficiency, only 1~2 minutes for each load
- The abrasive band mounted on the inner wall make the peeling clean
- Bottom with drainage outlet
- Clear window on top for easy observation



PP8
 Dimensions(LxWxH): 430x430x725mm
 Voltage: 220V/50Hz
 Power: 0.37Kw
 Bowl Volume: 8Kg
 N.W./G.W: 54/66Kgs

PP15
 Dimensions(LxWxH): 475x540x785mm
 Voltage: 220V/50Hz
 Power: 0.75Kw
 Bowl Volume: 15Kg
 N.W./G.W: 69/85Kgs

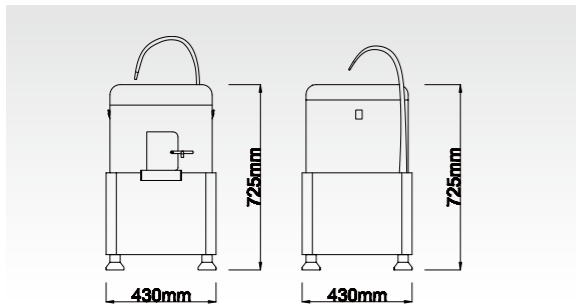

PP8

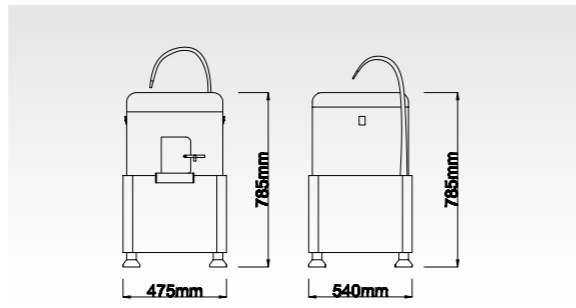

PP15A

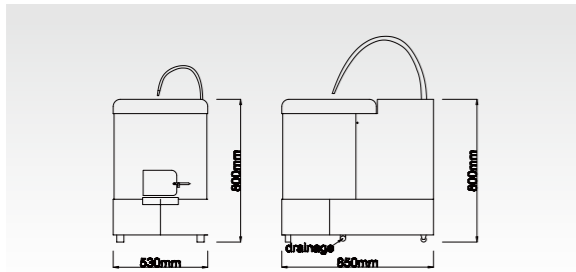

PP30

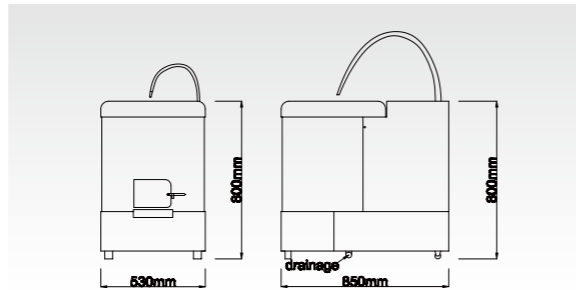

PP30A



PP8A
 Dimensions(LxWxH): 430x430x725mm
 Voltage: 220V/50Hz
 Power: 0.37Kw
 Bowl Volume: 8Kg
 N.W./G.W: 54/66Kgs



PP15A
 Dimensions(LxWxH): 475x540x785mm
 Voltage: 220V/50Hz
 Power: 0.75Kw
 Bowl Volume: 15Kg
 N.W./G.W: 69/85Kgs



PP30
 Dimensions(LxWxH): 850x530x800mm
 Voltage: 220V/50Hz
 Power: 1.5Kw
 Bowl Volume: 30Kg
 N.W./G.W: 122/148Kgs



PP30A
 Dimensions(LxWxH): 850x530x800mm
 Voltage: 220V/50Hz
 Power: 1.5Kw
 Bowl Volume: 30Kg
 N.W./G.W: 122/148Kgs

Meat Grinder

Meat Grinder

Description

- With two types of grinding blade
- High quality stainless steel material
- Heavy duty
- Skidproof rubber feet
- Totally-gear driving, compact structure and stable operation

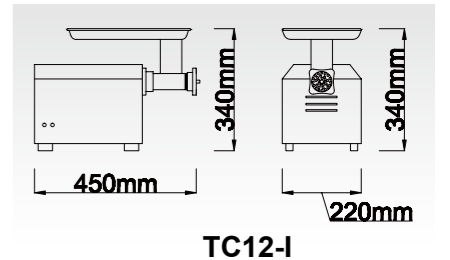

TC12-I



TC12-I

Dimension(LxWxH): 450x220x340mm
 Voltage: 220V/50Hz
 Power: 0.55Kw
 Production: 120Kg/h
 N.W./G.W: 31/37Kgs

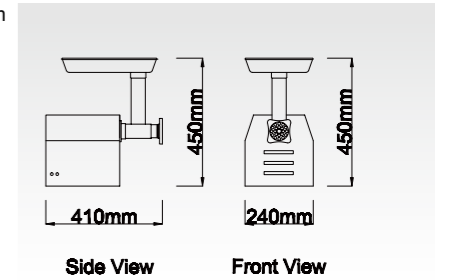

Side View Front View

TC22



TC22

Dimension(LxWxH): 410x240x450mm
 Voltage: 220V/50Hz
 Power: 0.75Kw
 Production: 220Kg/h
 N.W./G.W: 37/43Kgs



TC32

Dimension(LxWxH): 745x360x540mm
 Voltage: 380V/50Hz
 Power: 1.5Kw
 Production: 320Kg/h
 N.W./G.W: 94/108Kgs

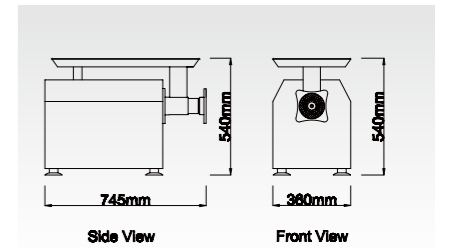

Side View Front View

TC32



Meat Grinder

TC42A

Dimension(LxWxH): 530x1020x950mm
 Voltage: 380V/50Hz
 Power: 4Kw
 Production capacity: 420Kg/h
 N.W./G.W: 167/197Kgs



Meat Grinder

TC42

Dimension(LxWxH): 530x1020x950mm
 Voltage: 380V/50Hz
 Power: 4Kw
 Production capacity: 420Kg/h
 N.W./G.W: 167/197Kgs



Meat Grinder

TC52

Dimension(LxWxH): 800x1350x1220mm
 Voltage: 380V/50Hz
 Power: 5.5Kw
 Production: 1300kg/h
 N.W./G.W: 418/481Kgs

Meat Grinder & Cheese Grinder

Description

- With two grinder blades and one cross blade
- Compact design, no sharp corner
- High grade stainless steel, meeting international hygienic standard
- Equipped with high efficient motor, cooling fan, precise gear drive and over load protection
- With forward-reverse switch, hard to be jammed



Meat Grinder & Cheese Grinder

CG22DM
 Dimension(LxWxH): 560x325x520mm
 Voltage: 220V/50Hz
 Power: 0.9Kw
 Mincer Production: 180Kg/h
 Cheese Grinder Production: 60Kg/h
 Grater opening size: 150x95mm
 N.W./G.W.: 25/27Kgs



Meat Grinder

MG32SD
 Dimension(LxWxH): 620x420x620mm
 Voltage: 220V/50Hz
 Power: 2.2Kw
 Production: 400Kg/h
 N.W./G.W.: 52/55 Kgs



Meat Grinder

MG12 HD
 Dimension(LxWxH): 485x365x485mm
 Voltage: 220V/50Hz
 Power: 0.75Kw
 Production: 120Kg/h
 N.W./G.W.: 31.5/34Kgs



Cheese Grinder

CG55SH
 Voltage: 220V/50Hz
 Power: 0.55Kw
 Capacity: 40Kg/h
 Grater opening size: 150x95mm
 N.W./G.W.: 15.5/16.5 Kgs
 Dimension(LxWxH): 490x325x485mm
 1: For grinding cheese only
 3: Feeding hole with cover and handle, safe to use
 4: No sharp corner



Meat Grinder

MG12 ID
 Dimension(LxWxH): 680x380x550mm
 Voltage: 220V/50Hz
 Power: 0.735Kw
 Capacity: 120Kg/h
 N.W./G.W.: 30/32 Kgs



Meat Grinder

MG22 HD
 Dimension(LxWxH): 575x410x590mm
 Voltage: 220V/50Hz
 Power: 0.9Kw
 Production: 220Kg/h
 N.W./G.W.: 39/46 Kgs



Meat Grinder

MG22 ID
 Dimension(LxWxH): 680x380x550mm
 Voltage: 220V/50Hz
 Power: 0.9Kw
 Capacity: 220Kg/h
 N.W./G.W.: 35.5 /37.5 Kgs



Meat Grinder

MG32 ID
 Dimension(LxWxH): 700x400x570mm
 Voltage: 220V/50Hz
 Power: 1.1Kw
 Capacity: 300Kg/h
 N.W./G.W.: 38/41Kgs



Meat Slicer & Dicer



Meat Slicer & Meat Dicer

TD180
 Dimension(LxWxH): 560x460x915mm
 Voltage: 220V/50Hz
 Power: 0.75Kw
 Cutting Thickness: 5mm
 N.W./G.W.: 77/93Kgs



Double Meat Slicer

TR180
 Dimension(LxWxH): 550x430x840mm
 Voltage: 220V/50Hz
 Power: 0.75Kw
 Cutting Thickness: 3mm, 5mm
 N.W./G.W.: 85/104Kgs



Robot Cutter

TZ-5
 Dimension(LxWxH): 500x620x600mm
 Voltage: 220V/50Hz
 Power: 1.5Kw
 Capacity: 5L
 Time setting: 0~5 minutes
 N.W./G.W.: 95/109Kgs

Meat Slicer

Description

- Imported Italian durable cutting blade
- High precision slicing thickness control
- Equipped with advanced protector, blade cover, hand protection for safety
- Skidproof feet to ensure safety



MS220 ST
 Dimension(LxWxH): 520x460x380mm
 Voltage: 220V/50Hz
 Power: 0.12Kw
 Cutting Thickness: 0-12mm
 N.W./G.W.: 14.1/15.2 Kgs

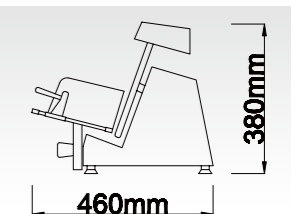
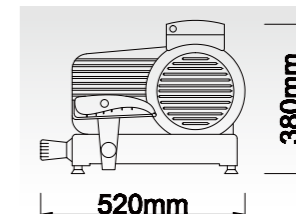

MS220 ST



MS250 ST
 Dimension(LxWxH): 520x460x380mm
 Voltage: 220V/50Hz
 Power: 0.15Kw
 Cutting Thickness: 0-12mm
 N.W./G.W.: 14.3/16 Kgs



MS275 ST
 Dimension(LxWxH): 570x460x395mm
 Voltage: 220V/50Hz
 Power: 0.2Kw
 Cutting Thickness: 0-12mm
 N.W./G.W.: 16.5/18 Kgs

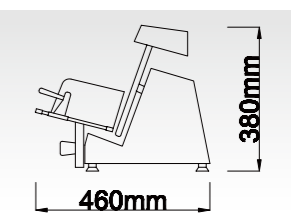
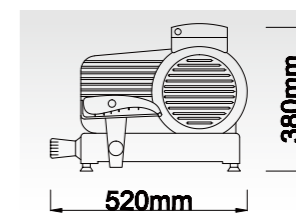

MS250 ST

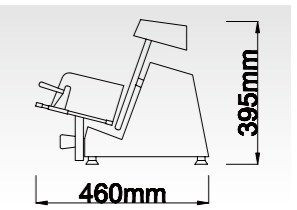
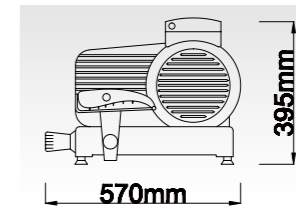

MS275 ST



MS300 ST
 Dimension(LxWxH): 630x530x460mm
 Voltage: 220V/50Hz
 Max Power: 0.25Kw
 Cutting Thickness: 0-12mm
 N.W./G.W.: 24.3/26 Kgs



MS220 SG
 Dimension(LxWxH): 520x460x380mm
 Voltage: 220V/50Hz
 Power: 0.12Kw
 Cutting Thickness: 0-12mm
 N.W./G.W.: 17/18Kgs



MS250 SG
 Dimension(LxWxH): 520x460x380mm
 Voltage: 220V/50Hz
 Rated Power: 0.15
 Cutting Thickness: 0-12mm
 N.W./G.W.: 19/20Kgs



MS300 SG
 Dimension(LxWxH): 630x530x460mm
 Voltage: 220V/50Hz
 Rated Power: 0.25Kw
 Cutting Thickness: 0-12mm
 N.W./G.W.: 26.5/28 Kgs

Sausage Filler

Sausage Filler

Description

- Filling speed can be controlled
- Hydraulic pressure system, low noise and fast.
- Equipped with knee-switch, convenient to operate
- With lockable wheel, easy to move.



SF-150
 Dimension(LxWxH): 600x400x1240mm
 Voltage: 220V/50Hz
 Power: 0.55Kw
 Bowl dia: Φ 200mm
 Productivity: 280kg/h
 Bowl Volume: 10L
 N.W: 75kgs



SF-260
 Dimension(LxWxH): 640x485x1240mm
 Voltage: 220V/50Hz
 Power: 0.75Kw
 Bowl dia: Φ 260mm
 Productivity: 400kg/h
 Bowl Volume: 17L
 N.W: 90kgs



SF-350
 Dimension(LxWxH): 735x560x1240mm
 Voltage: 220V/50Hz
 Power: 0.75Kw
 Bowl dia: Φ 320mm
 Productivity: 520kg/h
 Bowl Volume: 25L
 N.W: 105kgs



SF-8L
 Dimension(LxWxH): 400x540x980mm
 Bowl Volume: 8L
 N.W: 43kgs



SF-16L
 Dimension(LxWxH): 450x570x1120mm
 Bowl Volume: 16L
 N.W: 52kgs



SL-10V
 Dimension(LxWxH): 810x360x270mm
 N.W./G.W.: 19/22Kgs
 Capacity: 10L

SL-12V
 Dimension(LxWxH): 810x430x310mm
 N.W./G.W.: 31/34Kgs
 Capacity: 12L

SL-16V
 Dimension(LxWxH): 930x430x310mm
 N.W./G.W.: 32/35Kgs
 Capacity: 16L



SL-12H
 Dimension(LxWxH): 750x310x290mm
 N.W./G.W.: 28/31Kgs
 Capacity: 12L



SL-10H
 Dimension(LxWxH): 750x230x260mm
 N.W./G.W.: 17/20Kgs
 Capacity: 10L



SF-8
 Dimension(LxWxH): 730x220x280mm
 Bowl Volume: 8L
 N.W: 30kgs



SF-16
 Dimension(LxWxH): 860x260x320mm
 Bowl Volume: 16L
 N.W: 39kgs

SL-16H
 Dimension(LxWxH): 850x310x290mm
 N.W./G.W.: 31/34Kgs
 Capacity: 16L

Filling Mixer

Description

- Suitable for mixing stuffing to make dumpling, pie, sausage etc.
- Rotating direction can be clockwise & anti-clockwise to ensure the mixed filling completely
- Food contact parts are made by stainless steel, meeting international hygienic standard.



BX35A
 Dimension(LxWxH): 720x510x1050mm
 Voltage: 220V/50Hz
 Power: 0.75Kw
 Production: 35L / time
 N.W./G.W: 136/166Kgs



BX50A
 Dimension(LxWxH): 820x510x1100mm
 Voltage: 220V/50Hz
 Power: 1.1Kw
 Production: 50L / time
 N.W./G.W: 152/186Kgs



BX70A
 Dimension(LxWxH): 850x500x1100mm
 Voltage: 220V/50Hz
 Power: 1.5Kw
 Production: 70L / time
 N.W./G.W: 178/210Kgs



BX100A
 Dimension(LxWxH): 1010x556x1100mm
 Voltage: 220V/50Hz
 Power: 1.5Kw
 Production capacity: 100L / time
 N.W./G.W: 225/263Kgs



BX120A
 Dimension(LxWxH): 1100x660x1210mm
 Voltage: 380V/50Hz
 Power: 1.5Kw
 Production capacity: 120L / time
 N.W./G.W: 238/280Kgs



BX150A
 Dimension(LxWxH): 1100x660x1260mm
 Voltage: 380V/50Hz
 Power: 1.5Kw
 Production: 150L / time
 N.W./G.W: 265/330Kgs

Bone Saw Machine



CE



Bone Saw Machine JG210

Dimension(LxWxH): 520x490x840mm
Voltage: 220V/50Hz
Power: 0.5Kw
Belt Wheel Dia.: 210mm
Blade Speed: 15m/s
Table Size: 400x436mm
Cutting Thickness: 4~180mm
N.W/G.W: 50/69Kgs



CE

Bone Saw Machine JG210A

Dimension(LxWxH): 660x530x970mm
Voltage: 220V/50Hz
Power: 0.5Kw
Belt Wheel Dia.: 210mm
Blade Speed: 15m/s
Table Size: 610x530mm
Cutting Thickness: 4~180mm
N.W/G.W: 56/77Kgs



CE



Bone Saw Machine JG300A

Dimension(LxWxH): 780x710x1690mm
Voltage: 380V/50Hz
Power: 1.5Kw
Belt Wheel Dia.: 300mm
Blade Speed: 15m/s
Table Size: 712x662mm
Cutting Thickness: 30~250mm
N.W/G.W: 115/160Kgs



CE

Bone Saw Machine JG300

Dimension(LxWxH): 780x710x1690mm
Voltage: 380V/50Hz
Power: 1.5Kw
Belt Wheel Dia.: 300mm
Blade Speed: 15m/s
Table Size: 712x662mm
Cutting Thickness: 30~250mm
N.W/G.W: 115/160Kgs



INEO

Let Your Restaurant Start Easier!

Bakery Equipment

- Dough Mixer
- Food Mixer
- Electric Prover
- Dough Sheeter & Divider & Press Machine
- Noodle Machine & Bread Slicer
- Pizza Dough Roller & Toaster
- Electric Deck Oven
- Gas Deck Oven
- Electric Pizza Oven
- Convection Oven

CE UL RoHS UL US LISTED

