



JTGB

Bevel Gear Ball Screw Jack

Descriptions	001
Materials	002
Selection Guide	003 - 007
Selection Notes	003
Unit Converter	004
Sample Part Number	005
Specifications	008
Screw Jack System Configurations	009
Overall Dimensions	010 - 012
JTGB15 - JTGB19	010
JTGB25 - JTGB32	011
JTGB40 - JTGB45	012
Other Products	013 - 016
Contact Us	017

Contents

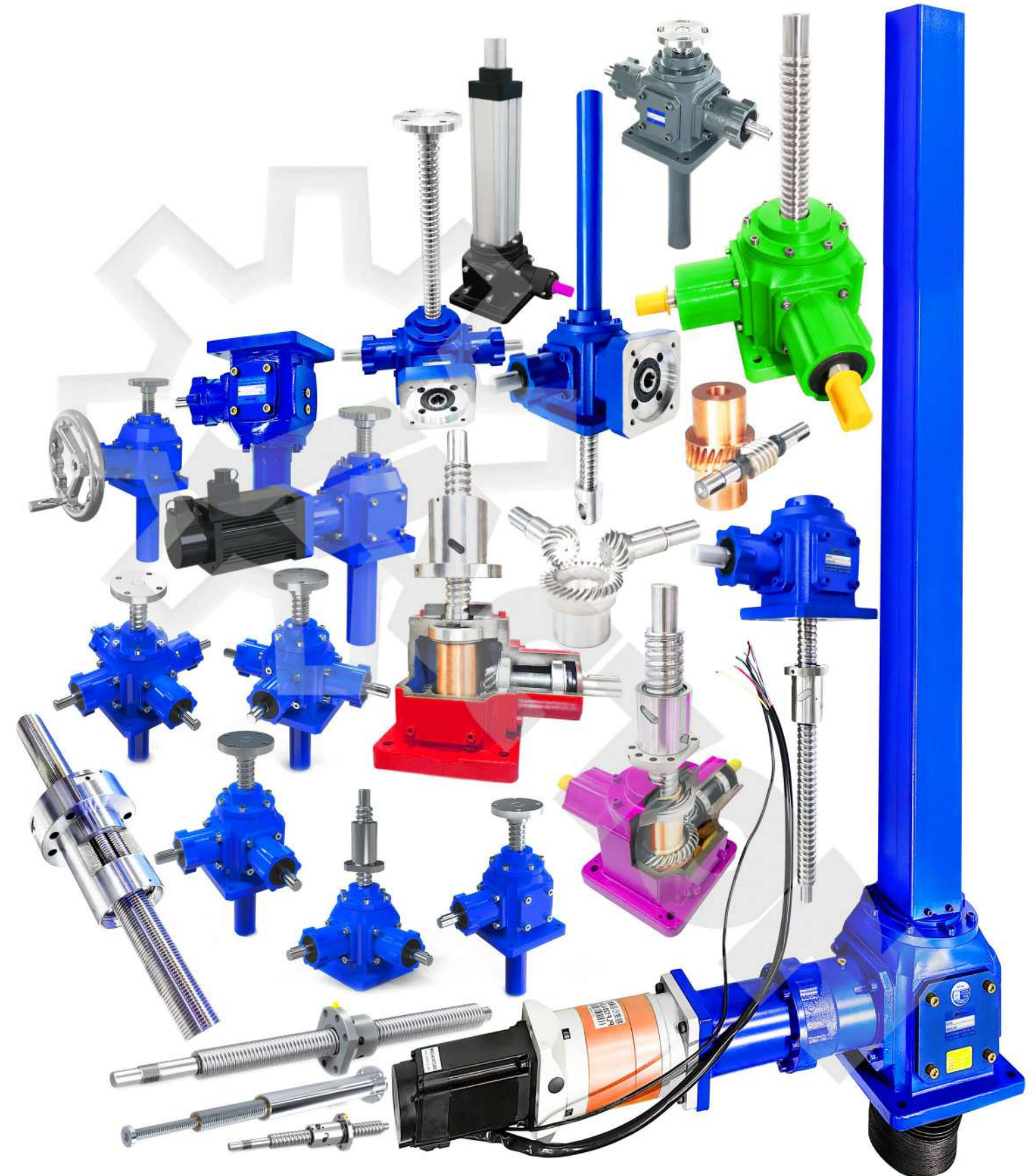

Descriptions

JACTON High Performance JTGB Series Bevel Gear Ball Screw Jacks are by the use of spiral bevel gears mechanism with high accuracy ball screws and nuts. Bevel gear ball screw jacks are more efficient and therefore require less power than a bevel gear machine screw jack in the same application. Because the ball screw and nut made from hardened alloy steel with hardened bearing balls carrying the load between the nut and the screw permitting smooth and efficient movement of the load. Because of the greater efficiency and rolling action, the ball screw can operate at higher speeds or increased duty cycle when compared with the Bevel Gear Machine Screw Jack. The addition of a high efficiency ball screw and nut reduces the required input torque to approximately one-third the torque required for the Bevel Gear Machine Screw Jack.

Bevel ball jacks supplement our offer of worm gear screw jacks. This design allows higher travel speeds and higher duty cycles than other mechanical worm gear screw jacks. Bevel ball jacks achieve fast travel speeds and are rated for near continuous operation, they are fastest jacks. For many applications, a ball screw model is the best choice. Bevel gear jacks design eliminates the need for right angle gearboxes in multiple screw jack systems. All bevel gear ball screw jacks can back drive (not self-locking) and require some means of holding the load, such as a brake on the motor. In addition to back driving, system inertia usually results in some over travel when the motor is switched off. The inertia of the system should be considered when determining the brake size required to stop a dynamic load.

- **Note:** hand wheels are not a recommended option.

Key Features

- Equipped with hardened spiral toothed bevel gear transmissions for high lifting speeds, greater duty cycles, high efficiency and long lifespan.
- Available in 6 sizes. Max. static load: 1 ton to 20 ton, Max. dynamic load: 300kg to 5 ton.
- There are no "standard" travel lengths and each bevel gear jack is built to specification, maximum stroke of 6 m
- Basic designs: Translating screw, Anti-rotation screw, and Rotating screw.
- Upright or Inverted mounting. Available in tension or compression loads.
- Standard with single lead ball screw, custom double or high lead ball screw which offers increased travel speed and require a brake or external locking device to hold position.
- Available in single shaft, two shaft and three shaft configurations. In two and three shaft configurations, the jack offers right angle characteristics with the ability to divide input power or torque, sending it equally in different directions.
- Power source: electrically by brake motor driven.
- Easy synchronized operation: System design such as the simultaneous operation of multiple jacks is easy.
- Optimal for low-speed operation: The driving system has less noise because machinery can be driven at a lower input speed.
- Simple and effective solution in comparison with hydraulic and pneumatic systems.
- Higher efficiency, higher lifting speed, higher duty cycle, longer lifespan.

Materials

We use the best materials to guarantee the performance and lifetime of the bevel gear ball screw jacks you purchased.

Spiral Bevel Gears

- Lapped together in pairs, high quality alloy steel, case hardened.

Ball Screw

- SCM 450, S55C, Hardness: HRC 58-62.

Ball Nut

- SCM415H, Hardness: HRC 58-62.

Ball

- SUJ2, Hardness: HRC 60 UP.

Input Shaft (Worm)

- Hardened, alloy steel. Custom Stainless Steel 304 or 316.

Housing

- High-strength Casting Housing, Ductile Iron.

Drive Sleeve

- High Strength Bronze ZQA19-4 (Casting aluminum bronze) as Standard, Custom High Strength Bronze ZCuSn10Pb(Casting tin bronze)

Bearing

- Anti-friction Tapered Roller Bearings. Custom Stainless Steel 304.



Selection Guide

Selection Notes

- (01) Bevel Gear Screw Jacks and Lifting Systems are for industrial use only, not recommended for transporting personnel.
- (02) Carefully consider bevel gear jack ratings before making a selection. Be sure that the dynamic or static load carried or sustained by jack does not exceed its maximum capacity.
- (03) Carefully consider the combination of screw shaft speed (rpm) and rated load. Also, take extra care in verifying rated buckling load and screw shaft speed (rpm). Exceeding the data provided in this catalog can cause major damage to the system.
- (04) Make sure that the surface temperature of the housing does not exceed temperature of -15°C to +80°C during operation. If using a traveling nut jack, measure the traveling nut surface temperature. Make sure all the rotating parts are completely stopped before proceeding to measure.
- (05) The maximum input speed is 1500 rpm as long as the input power does not exceed the jack's maximum allowable input power.
- (06) Bevel Gear Jack can not be operated continuously. Duty cycle based on 30 minutes.
- **Note:** Below duty cycles are based on ambient temperatures 20°C. For ambient temperatures higher than 20 °C, the duty cycle (ED) must be reduced.
 - * Screw Jack with Trapezoidal Screw (Bevel Gear Machine Screw Jack) duty cycle ≤ 35%ED.
 - * Screw Jack with Ball Screw (Bevel Gear Ball Screw Jack) duty cycle ≤ 60%ED.
 - **Note:** For operation longer than that mentioned above or for any continuous operation, the jacks temperature must be monitored and should not exceed 80°C maximum in order to determine its duty cycle.
- Duty Cycle (%ED) = [1 Duty Cycle / (1 Duty Cycle + 1 Rest Cycle)] x 100%**
- (07) Be sure not to exceed the maximum input torque for multiple screw jack systems by verifying the rated input torque for each jack.
- (08) Be sure that starting torque is 200% or more of required running torque.
- (09) Be sure that ample driving power is available to drive the jack when using in temperatures below 0°C. Low temperatures decrease the jack's efficiency due to the increased grease viscosity inside the jack's gearbox.

Selection Guide

- (10) Although Screw Jack with **Single-start** Trapezoidal Screw (Bevel Gear Machine Screw Jack) has self-locking feature, vibration and shock may affect its efficiency, in which case a brake motor or extra braking device is required. Screw Jack with **Double-start** Trapezoidal Screw (Bevel Gear Machine Screw Jack) is considered not self-locking will require a brake or other holding device. Screw Jack with Ball Screw (Bevel Gear Ball Screw Jack) can backdrive because of their extremely high efficiencies and require some means of holding the load, such as a brake motor.
- (11) When jacks are working, can not force to stop, may result in the jacks damage or injury personnel.
- (12) When Bevel Gear Ball Screw Jack are under loads, can not change the motor drive to manual operation. Because the loads will cause the input shaft to rotate very dangerously.
- (13) Mechanical stops (Stop Nuts) are not provided on the lifting screw unless requested. Therefore, it is possible to drive the screw out of the jack's housing
- (14) Never approach or touch the rotary parts (input shaft, etc.) or the lifting screw during operation.
- (15) Bellows Boots and Protective Tubes should be used to protect and keep the lifting screw clean in dusty or abrasive environments.

Unit Converter

- 1 ft = 304.8 mm
- 1 in = 25.4 mm
- 1 m = 10 dm = 100 cm = 1000 mm
- 1 in-lb = 0.113 Nm
- 1 Nm = 0.737 ft-lb
- 1 ft-lb = 1.356 Nm
- 1 lb = 0.454 kg
- 1 kg = 2.205 lb = 1000 g
- 1 N = 0.1 kg
- 1 t = 1000 kg = 10 kN = 2000 lb
- 1 m/min = 1000 mm/min = 16.7 mm/sec
- 1 in/sec = 25.4 mm/sec
- 1 ft/sec = 304.8 mm/sec
- 1 hp = 0.75 kW
- °C = (°F-32) / 1.8
- °F = °C x 1.8 + 32

Selection Guide

Sample Part Number (Example):

JTGB25 - US - 300 - 2 - II - 2SR - CU - PP
(1) (2) (3) (4) (5) (6) (7) (8)

(1) Models & (4) Gear Ratios

JTGB15 (BS 20x5 / BS 20x10) 2.5:1 ratio	JTGB19 (BS 32x10 / 32x20) 2.5 : 1 ratio	JTGB25 (BS 40x10 / 40x20) 3: 1 ratio
JTGB32 (BS 50x10 / 50x20) 3: 1 ratio	JTGB40 (BS 63x10 / 63x20) 3: 1 ratio	JTGB45 (BS 80x10 / 80x20) 3: 1 ratio

(2) Basic Designs and Configurations

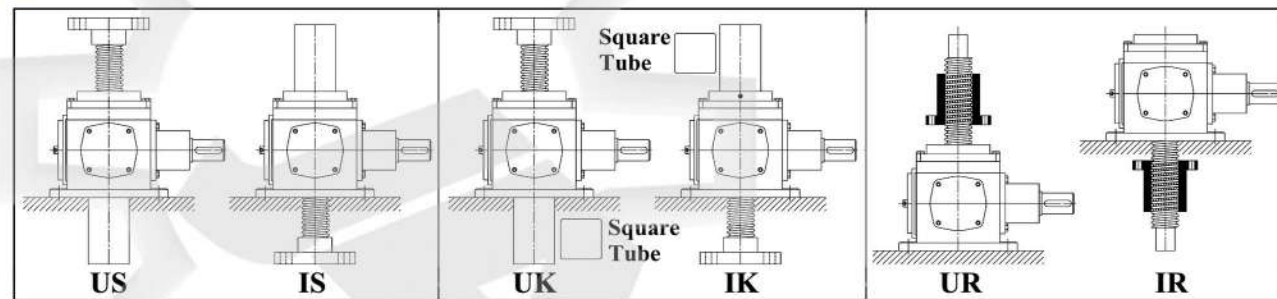

2.1) "US" and "IS" are Translating Bevel Gear Ball Jacks. A translating jack has a lifting screw that moves through the gearbox. A nut is integrated with the bevel gear such that the bevel gear and nut rotate together. When the lifting screw is held to prevent rotation through the use of guides (guided load) or by attaching a common load across multiple jacks, the lifting screw will move linearly through the gearbox to move the load. Most applications use this jack design.

2.2) "UK" and "IK" are Anti-rotation Bevel Gear Ball Jacks. They are attached Square Guide Tube for non-rotation. A square guide tube is attached to either the top or bottom of the Screw Jack. A square nut is attached to the end of the Lifting Screw which is then fitted inside the tube, preventing rotation. The Square Guide Tube is supplied with lube fittings. It is ideal for use in applications where a single jack must extend to meet and move a load to which it is not attached (unguided). Anti-rotating jacks are mostly used on larger Jacks and where the lifting force is high in relationship to the nominal capacity or where the travel is long.

• **Note:** Input torque required will increase by approximately 8%.

2.3) "UR" and "IR" are Rotating Bevel Gear Ball Jacks. A rotating jack has a lifting screw that moves a nut as it turns. It is important to restrain the rotation of the traveling nut by applying a significant load, or more commonly by guiding the load or attaching the load across multiple jacks. The lifting screw is fixed to the bevel gear. This causes the load, which is attached to the travel nut, to move along the Lifting screw. The Rotating Jacks mount flush and they are ideal for applications where the physical space does not allow the lifting screw to extend below or above the housing.

Selection Guide

(3) Stroke and (5) Screw End Fittings

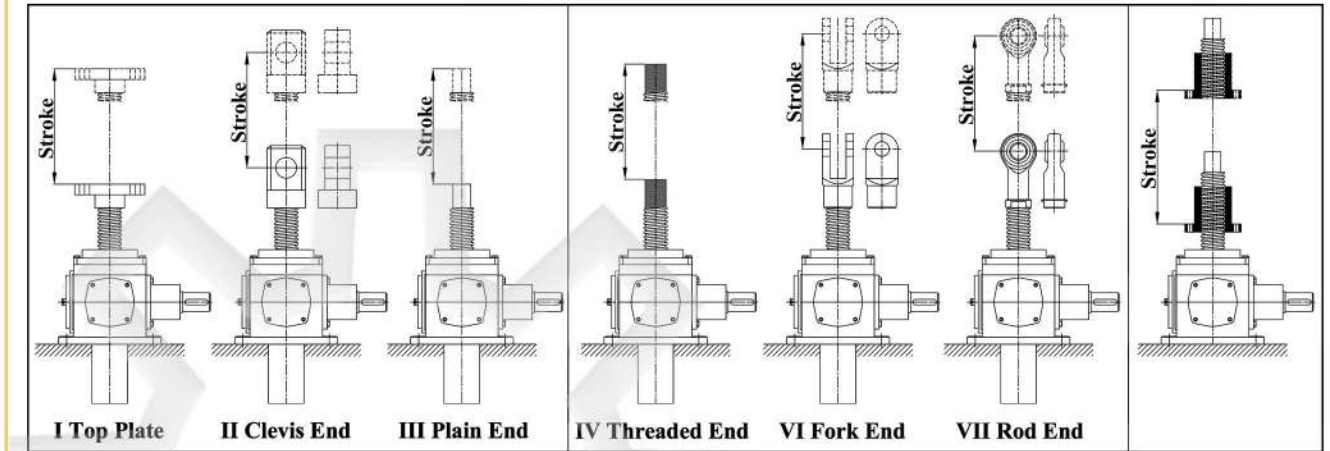

- Stroke is travel expressed in millimeter(mm) or inches and not the actual screw length.
- Standard Lifting Screw End Fittings: Top Plate (I), Clevis End (II), Plain End (III), Threaded End (IV), Forked End (VI) and Rod End (VII). Custom End Fittings are acceptable.

(6) Input Shafts Codes and Motor Flange Adapters Codes (Top View)

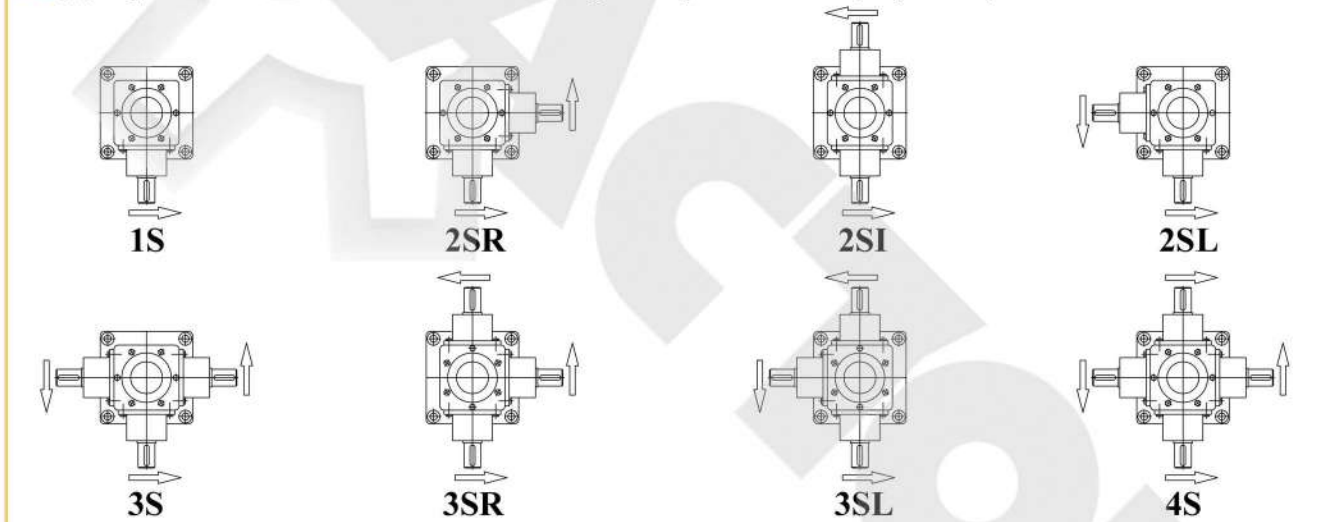

(7) Gears Mounting Postions

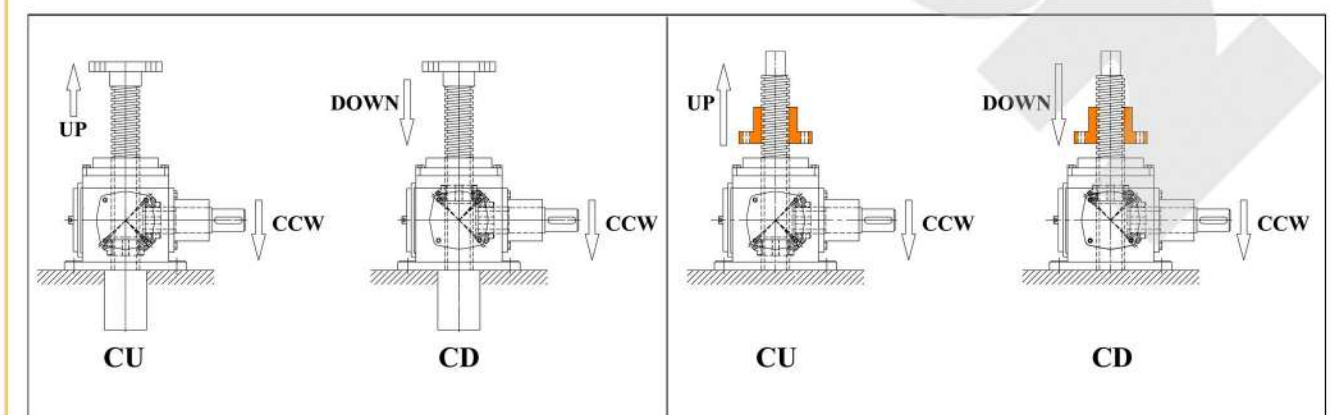

Selection Guide

Sample Part Number

(7) Accessories



Specifications

Remarks:

- 1) Overall efficiency is under grease lubrication.
- 2) Not self-locking, brake motor is required.
- 3) They maximum dynamic load is under Euler II(fully guided).

Model	JTGB15	JTGB19	JTGB25	JTGB32	JTGB40	JTGB45
Maximum static load capacity (kgf)	1000	3000	5000	10000	15000	20000
Maximum dynamic load capacity (kgf)	300	1000	1500	2500	3500	5000
Ball screw sizes (mm)	20 x 5 20 x 10	32 x 10 32 x 20	40 x 10 40 x 20	50 x 10 50 x 20	63 x 10 63 x 20	80 x 10 80 x 20
Gear ratio	2.5:1	2.5:1	3:1	3:1	3:1	3:1
One Turn of Input Shaft, Travel (mm)	2 4	4 8	3.33 6.67	3.33 6.67	3.33 6.67	3.33 6.67
Overall Efficiency %	60%					
Ball Nut Material	Gcr15					
Housing material	Ductile Iron					

Screw Jack System Configurations

Two Jacks



Four Jacks



Six Jacks



Eight Jacks



Fourteen Jacks



Overall Dimensions

JTGB15

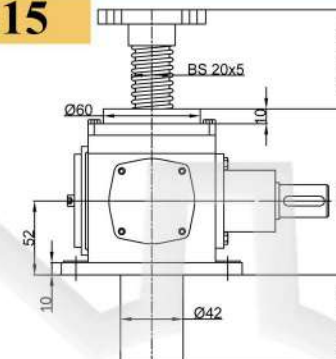

Upright

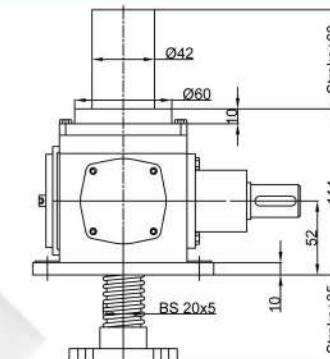

Inverted

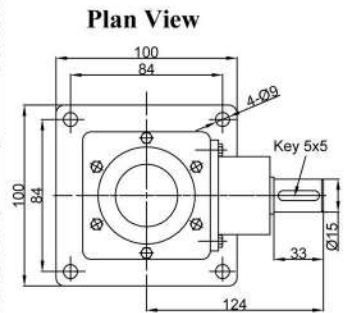

Plan View

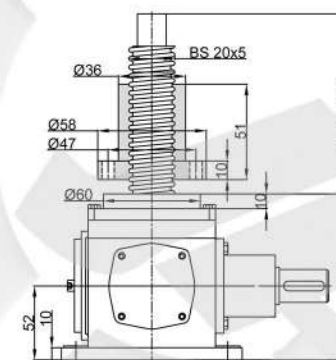

Upright

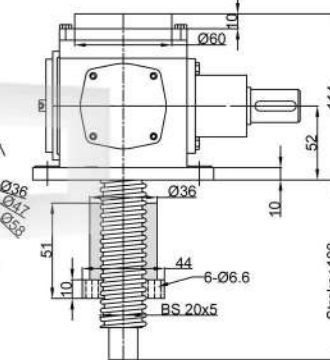

Inverted

Screw End Types and Dimensions

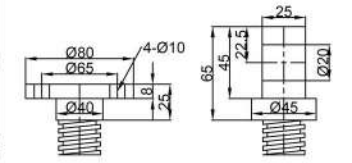

I Top Plate II Clevis End



III Plain End IV Thread End

JTGB19

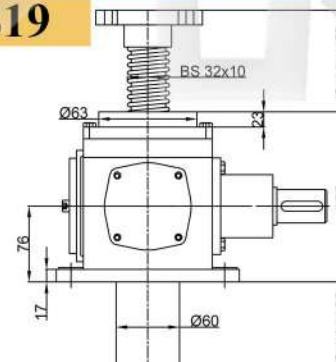

Upright

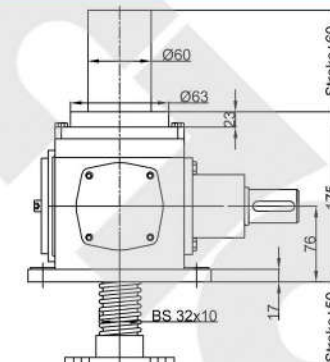

Inverted

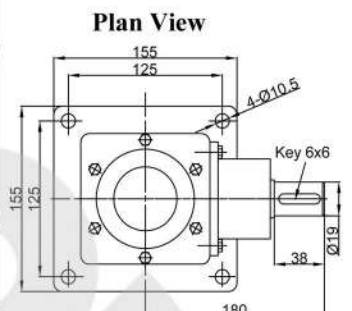

Plan View

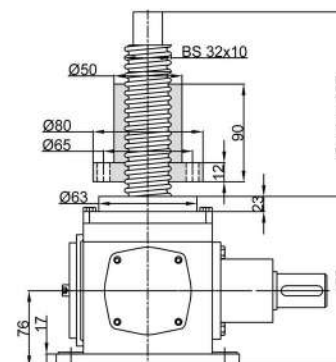

Upright

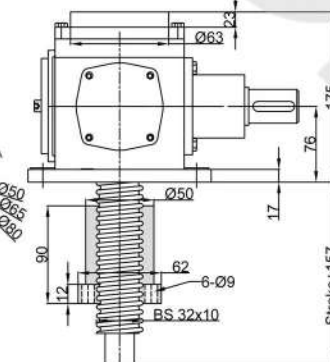

Inverted

Screw End Types and Dimensions

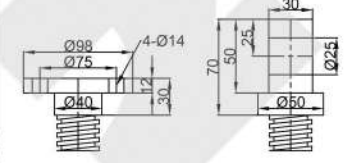

I Top Plate II Clevis End



III Plain End IV Thread End

*. Dimensions are subject to change without notice

Overall Dimensions

JTGB25

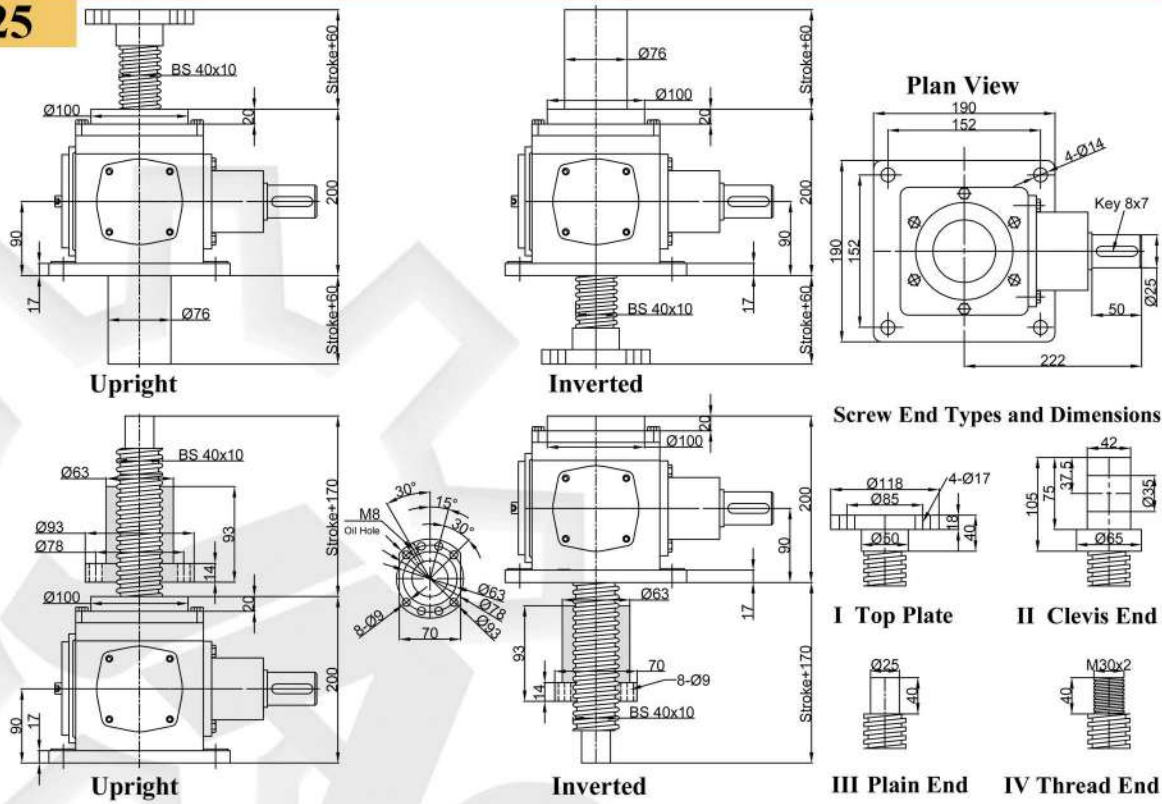

JTGB32

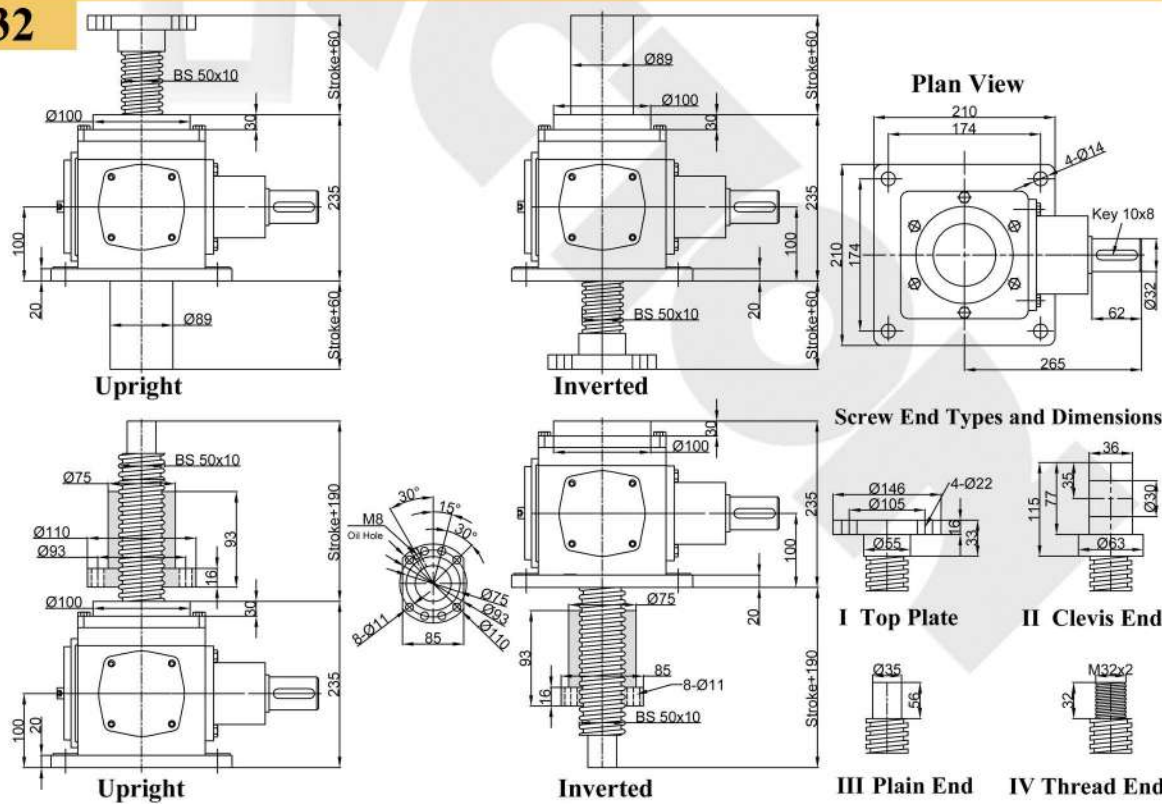

*. Dimensions are subject to change without notice

Overall Dimensions

JTGB40

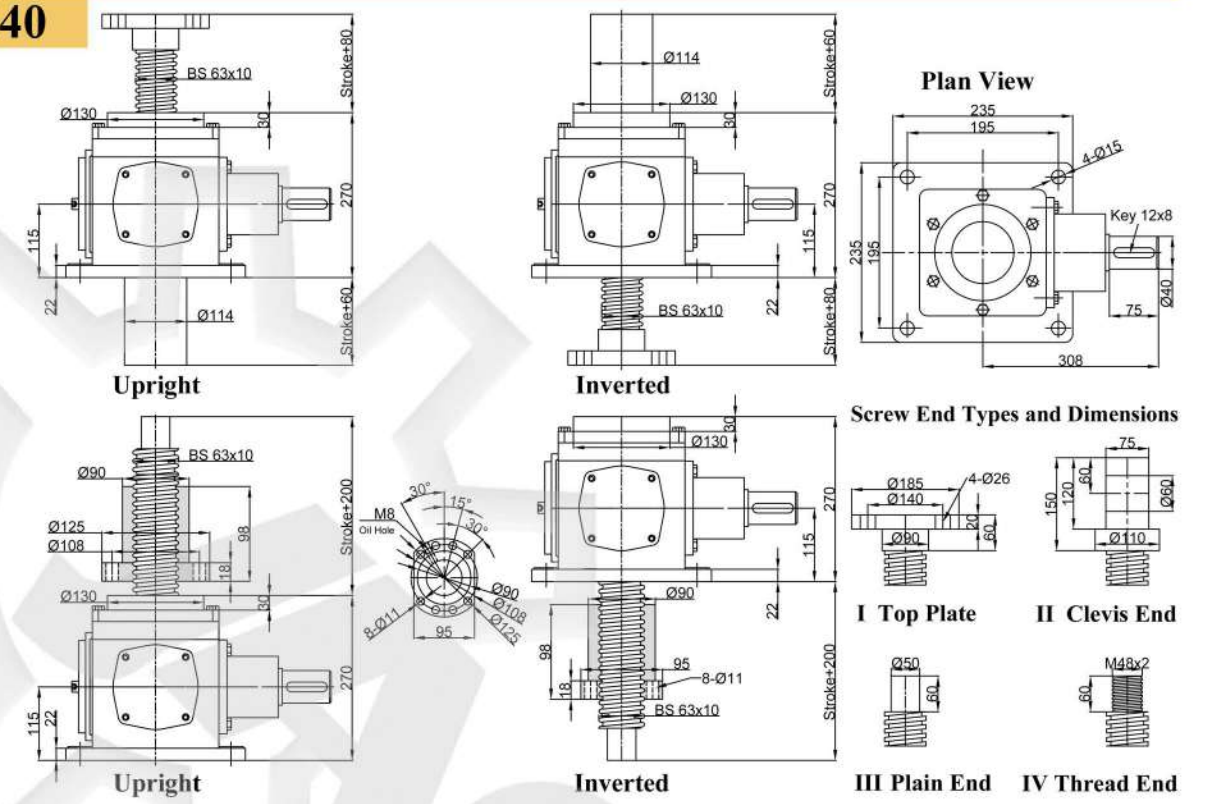

JTGB45

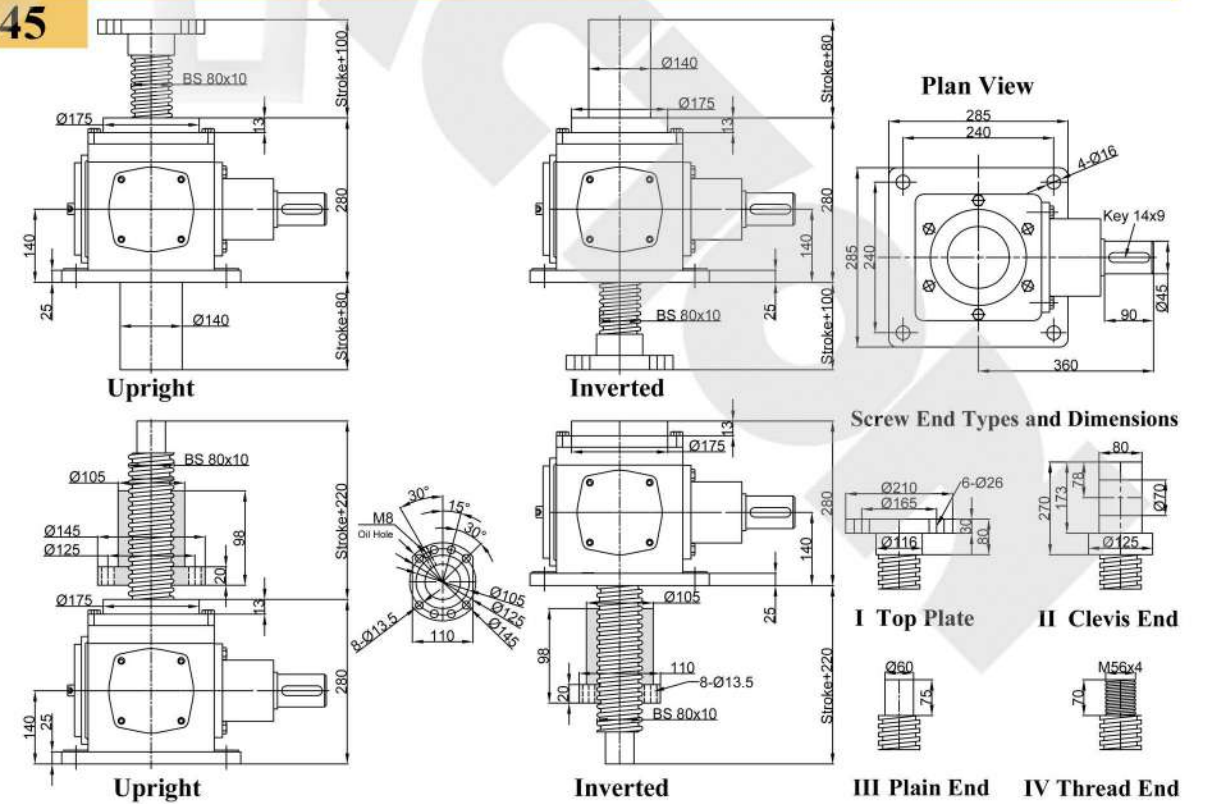

*. Dimensions are subject to change without notice

Other Products

Cubic Machine Screw Jack

- Cubic design permits any mounting position.
- High static loads, best for slow movement and low duty cycles.
- Static load capacities from 2.5 kN to 500 kN as Standard.
- Translating, Anti-rotation (keyed) and Rotating Screw configurations.
- Self locking trapezoidal screw offers maximum stroke of 7500 mm.
- Power source: Manual operation, Motor drive.
- Single jack, or synchronization of multiple jacks arrangement



Cubic Ball Screw Jack

- Cubic design permits any mounting position.
- High duty cycle, high precision, high speed, less power and long service life.
- Static load capacities from 10 kN to 350 kN as Standard.
- Translating, Anti-rotation and Rotating Screw configurations.
- Not self-locking ball screw offers maximum stroke of 6000 mm.
- Power source: Brake motor drive. Not suited for manual operation.
- Single jack, or synchronization of multiple jacks arrangements.



Classic Machine Screw Jack

- Classic design, no need to attach any construction elements to the housing.
- High static loads, best for slow movement and low duty cycles.
- Static load capacities from 0.5 ton to 100 tons as Standard.
- Translating, Anti-rotation (keyed) and Rotating Screw configurations.
- Self locking trapezoidal screw offers maximum stroke of 7500 mm.
- Power source: Manual operation, Motor drive.
- Single jack, or synchronization of multiple jacks arrangements.



Stainless Steel Screw Jack

- Classic design, no need to attach any construction elements to
- Complete Stainless Steel Screw Jack design.
- High static loads, best for slow movement and low duty cycles.
- Static load capacities from 1 ton to 20 tons as Standard.
- Translating, Anti-rotation (keyed) and Rotating Screw configurations.
- Self locking Stainless Steel trapezoidal screw offers maximum stroke of 7500 mm.
- Power source: Manual operation, Motor drive.
- Single jack, or synchronization of multiple jacks arrangements.



Other Products

Classic Ball Screw Jack

- Classic design, no need to attach any construction elements to the housing.
- High duty cycle, high precision, high speed, less power and long service life.
- Static load capacities from 1 ton to 35 tons as Standard.
- Translating, Anti-rotation and Rotating Screw configurations.
- Not self-locking ball screw offers maximum stroke of 6000 mm.
- Power source: Brake motor drive. Not suited for manual operation
- Single jack, or synchronization of multiple jacks arrangements.



Bevel Gear Machine Screw Jack

- High efficiency, high lifting speed, high duty cycle, long lifespan.
- Spiral bevel gear mechanism are used, with 2:1, 2.5:1 and 3:1 ratios.
- Static load capacities from 400 Kg to 3500 Kg as Standard.
- Translating, Anti-rotation (keyed) and Rotating Screw configurations.
- Self locking trapezoidal screw offers maximum stroke of 6000 mm.
- Power source: Manual operation, Motor drive.
- Single jack, or synchronization of multiple jacks arrangement



Bevel Gear Ball Screw Jack

- Higher efficiency, higher lifting speed, higher duty cycle, longer lifespan.
- Spiral bevel gear mechanism are used, with 2:1, 2.5:1 and 3:1 ratios.
- Static load capacities from 400 Kg to 3500 Kg as Standard.
- Translating, Anti-rotation and Rotating Screw configurations.
- Not self-locking ball screw offers maximum stroke of 6000 mm.
- Power source: Brake motor drive. Not suited for manual operation.
- Single jack, or synchronization of multiple jacks arrangements.



Screw Jack Lifting Systems

- Lifting systems are not limited to the number of screw jacks. Commonly used are 2, 4, 6, 8 jack systems.
- Full synchronization, self-locking, precision positioning, easy installation and operation, maintenance free.
- From a few kilograms to heavy-duty several hundred tons.
- Complete lifting systems with geared motors, shafting and couplings available.
- Power source: Synchronized drive from a single electric motor.
- With Inverter driven motor, soft start and stop, variable lifting speeds are all available.



Other Products

Cubic Bevel Gearbox

- Modular design spiral bevel gearboxes with cubic housing.
- Ultra Compact Design. All-round tapped holes for universal mounting, 6 possible mounting positions.
- Gear ratios of 1:1, 2:1, 3:1, 4:1 and 5:1 are actual ones.
- Power Ratings up to 156 kW. Torque Ratings up to 1199 N.m.
- Gear transmission average efficiency up to 94%.
- 2-way, 3-way and 4-way Configurations.
- Solid Shaft, Hollow Shaft, and Direct motor mount or via motor flanges.
- High efficiency, high transmission capacity, low backlash, Noiseless operation, low running temperature and long service life.



Classic Bevel Gearbox

- Used in pairs case hardened alloy steel spiral bevel gears.
- Gear ratios of 1:1, 1.5:1, 2:1, 2.5:1, 3:1, 4:1 and 5:1 are actual ones.
- Power Ratings up to 335 kW. Torque Ratings up to 5713 N.m.
- Gear transmission average efficiency up to 94%.
- 2-way, 3-way and 4-way Configurations.
- Solid Shaft, Hollow Shaft, and Direct motor mount or via motor flanges.
- Various Shafts Arrangements, Rotation Directions and Mounting Positions available.
- High efficiency, high transmission capacity, low backlash, noiseless operation, low running temperature and long service life.



Lightweight Bevel Gearbox (Aluminium Alloy)

- Quality finished casing by die-casting, in lightweight aluminium alloy.
- Compact design, small-sized, ultra-lightweight, universal mounting.
- Utilizing carburized case-hardened spiral bevel gears
- Gear ratios of 1:1 and 2:1 are actual ones.
- Power Ratings up to 4.94 kW. Torque Ratings up to 40 N.m.
- Gear transmission average efficiency up to 94%.
- 2-way and 3-way Configurations.
- High efficiency, low backlash, quiet operation, maintenance free, low running temperature and long service life.



Other Products

Electric Cylinders

- Be basically screw jacks with travelling nut, but with lifting cylinder design.
- High static loads, best for slow movement and low duty cycles.
- Static load capacities from 2.5 ton to 10 tons as Standard.
- Self-locking, precise positioning, and uniform speed.
- Power source: Manual operation, Motor drive.
- Single unit, or synchronization of multiple units.
- A better choice over hydraulic actuators or pneumatic cylinders with this clean alternative, simpler to install, control, low maintenance and a quieter solution.



Electric Linear Actuators

- Parallel or In-Line drive configurations.
- Self-locking ACME screw and nut, driven by an electric motor, through a reduction gearbox.
- Low maintenance due to high-quality grease and enclosed design.
- Load capacities from 100 Kgf to 15 tons as Standard (Parallel)
- Load capacities from 10 Kgf to 1000 Kgf as Standard (In-Line).
- Low noise system, higher dynamic capacity, higher speed capability and longer life.
- Low power consumption and running costs, no oil leaks, contamination or fire risk.
- Easy installation with two trunnion mounting feet, no pipework, powerpack and valves.
- Be a real alternative to pneumatic and hydraulic cylinders.



Customized and molded products

